



YCHIOT

DWM1000

DATASHEET

**Compatible with Qorvo DWM1000
Medium range UWB RF module**

Version V1.2

PRODUCT INTRODUCTION

The DWM1000 module is based on Qorvo DW1000 Ultra Wideband (UWB) transceiver IC. It integrates antenna, all RF circuitry, power management and clock circuitry in one module. It can be used in TWR(Two Way Ranging) or TDOA location systems to locate assets to a precision of 10 cm and supports data rates of up to 6.8 Mbps.



KEY FEATURES

- IEEE 802.15.4-2011 UWB compliant
- Supports 4 RF bands from 3.5 GHz to 6.5 GHz
- Programmable transmitter output power
- Fully coherent receiver for maximum range and accuracy
- Designed to comply with FCC & ETSI UWB spectral masks
- Supply voltage from 2.8 V to 3.6 V
- Low power consumption
- Data rates of 110 kbps, 850 kbps, 6.8 Mbps
- Maximum packet length of 1023 bytes for high data throughput applications
- Integrated MAC support features
- Supports TWR and TDOA
- SPI interface to host processor
- 23 mm x 13 mm x 2.9 mm 24pin side castellation package

KEY BENEFITS

- Simplifies integration, no RF design required
- Very precise location of tagged objects delivers enterprise efficiency gains and cost reductions
- Extended communications range minimizes required infrastructure in RTLS
- High multipath fading immunity
- Supports very high tag densities in RTLS
- Low cost allows cost-effective implementation of solutions
- Low power consumption reduces the need to replace batteries and lowers system lifetime costs

APPLICATIONS

- Precision real time location systems (RTLS) using TWR or TDOA schemes in a variety of markets.
- Location aware wireless sensor networks (WSNs)

DWM1000-SMA IEEE 802.15.4-2011 UWB Transceiver Module

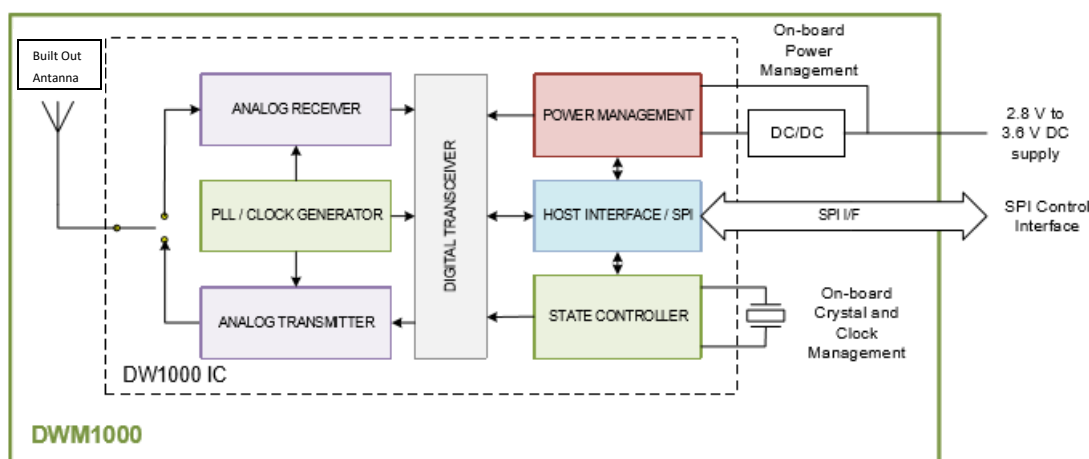

High Level Block Diagram

Contents

1	DWM1000 OVERVIEW	3
1.1	DWM1000 FUNCTION DESCRIPTION	3
1.2	DWM1000 POWER UP	3
1.3	SPI HOST INTERFACE	4
1.4	GENERAL PURPOSE INPUT OUTPUT (GPIO)	5
1.5	ALWAYS-ON (AON) MEMORY	5
1.6	ONE-TIME PROGRAMMABLE (OTP) MEMORY	6
1.7	INTERRUPTS AND DEVICE STATUS	6
1.8	MAC	6
2	DWM1000 CALIBRATION	7
2.1	DWM1000 CALIBRATION	7
3	DWM1000 PIN CONNECTIONS	8
3.1	PIN NUMBERING	8
3.2	PIN DESCRIPTIONS	8
4	ELECTRICAL SPECIFICATIONS	11
4.1	NOMINAL OPERATING CONDITIONS	11
4.2	DC CHARACTERISTICS	11
4.3	RECEIVER AC CHARACTERISTICS	12
4.4	RECEIVER SENSITIVITY CHARACTERISTICS	12
4.5	REFERENCE CLOCK AC CHARACTERISTICS	12
4.6	TRANSMITTER AC CHARACTERISTICS	13
4.7	TEMPERATURE AND VOLTAGE MONITOR CHARACTERISTICS	14
4.8	ANTENNA PERFORMANCE	14
4.9	ABSOLUTE MAXIMUM RATINGS	14
5	APPLICATION INFORMATION	15
5.1	APPLICATION BOARD LAYOUT GUIDELINES	15
5.2	APPLICATION CIRCUIT DIAGRAM	15
6	PACKAGE INFORMATION	18
6.1	MODULE DRAWINGS	18
6.2	MODULE RECOMMENDED PACKAGE	19
7	SMT PRODUCTION AND STORAGE	20
7.1	SMT PRODUCTION	20
7.2	STORAGE	20
8	ORDERING INFORMATION	22
9	GLOSSARY	23
10	DOCUMENTATION	25

DOCUMENT INFORMATION**Disclaimers**

YCHIOT reserves the right to change product specifications without notice. As far as possible changes to functionality and specifications will be issued in product specific errata sheets or in new versions of this document. Customers are advised to check the latest product description documents on the official website of YCHIOT.

LIFE SUPPORT POLICY

YCHIOT products are not authorized for use in safety-critical applications (such as life support) where a failure of the YCHIOT product would reasonably be expected to cause severe personal injury or death. YCHIOT customers using or selling YCHIOT products in such a manner do so entirely at their own risk and agree to fully indemnify YCHIOT and its representatives against any damages arising out of the use of YCHIOT products in such safety-critical applications.



Caution! ESD sensitive device. Precaution should be used when handling the device in order to prevent permanent damage.

REGULATORY APPROVALS

All products developed by the user incorporating the DWM1000 must be approved by the relevant authority governing radio emissions in any given jurisdiction prior to the marketing or sale of such products in that jurisdiction and user bears all responsibility for obtaining such approval as needed from the appropriate authorities.

1 DWM1000 OVERVIEW

The DWM1000 module is an IEEE 802.15.4-2011 UWB implementation. RF components, Qorvo DW1000 UWB transceiver, and other components reside on-module. DWM1000 enables cost effective and reduced complexity integration of UWB communications and ranging features, greatly accelerating design implementation.

1.1 DWM1000 Function Description

The DW1000 on board the DWM1000 is a fully integrated low-power, single chip CMOS RF transceiver IC compliant with the IEEE 802.15.4-2011 [1] UWB standard. The DWM1000 module requires no RF design as the antenna and associated analog and RF components are on the module.

The module contains an on-board 38.4 MHz reference crystal. The crystal has been trimmed in production to reduce the initial frequency error to approximately 2 ppm, using the DW1000 IC’s internal on-chip crystal trimming circuit, see section 2.1.1.

Always-On (AON) memory can be used to retain DWM1000 configuration data during the lowest power operational states when the on-chip voltage regulators are disabled. This data is uploaded and downloaded automatically. Use of DWM1000 AON memory is configurable.

The on-chip voltage and temperature monitors allow the host to read the voltage on the VDDAON pin and the internal die temperature information from the DW1000.

See the DW1000 Datasheet [2] for more detailed information on device functionality, electrical specifications and typical performance.

1.2 DWM1000 Power Up

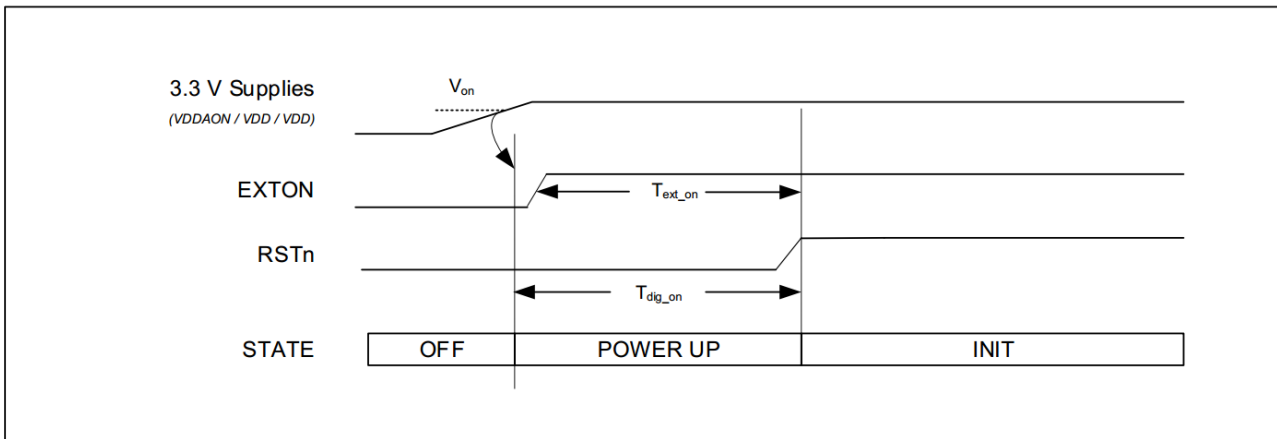

Figure 1 DWM1000 Power-up Sequence

When power is applied to the DWM1000, RSTn is driven low by internal circuitry as part of its power up sequence. See Figure 1 above. RSTn remains low until the on-module crystal oscillator has powered up and its output is suitable for use by the rest of the device, at which time RSTn is deasserted high.

Table 1: DW1000 Power-up Timings

Parameter	Description	Nominal Value	Units
V _{ON}	Voltage threshold to enable power up	2.0	V

T _{EXT_ON}	Time at which EXTON goes high before RSTn is released	3	ms
T _{DIG_ON}	RSTn held low by internal reset circuit / driven low by external reset circuit	3	ms

RSTn may be used as an output to reset external circuitry as part of system bring-up as power is applied.

An external circuit can reset the DWM1000 by asserting RSTn for a minimum of 10 ns. RSTn is an asynchronous input. DW1000 initialization will proceed when the pin is released to high impedance. **RSTn should never be driven high by an external source.**

Please see DW1000 Datasheet [2] for more details of DW1000 power up.

1.3 SPI Host Interface

The DW1000 host communications interface is a slave-only SPI. Both clock polarities (SPIPOL=0/1) and phases (SPIPHA=0/1) are supported. The data transfer protocol supports single and multiple byte read/writes accesses. All bytes are transferred MSB first and LSB last. A transfer is initiated by asserting SPICSn low and terminated when SPICSn is deasserted high.

See the DW1000 Datasheet [2] for full details of the SPI interface operation and mode configuration for clock phase and polarity.

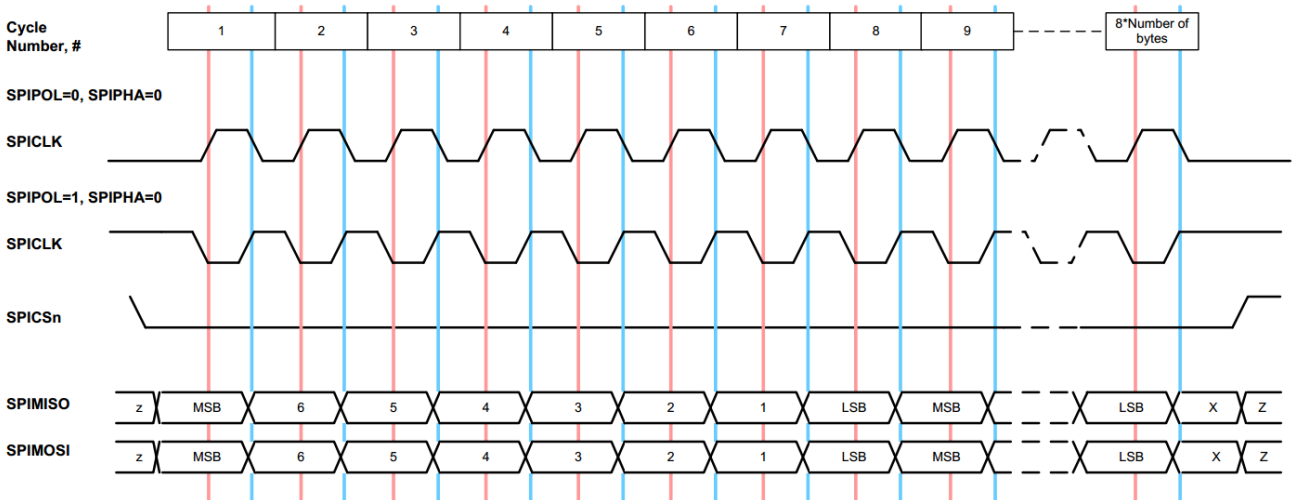

Figure 2 DW1000 SPIPHA=0 Transfer Protocol

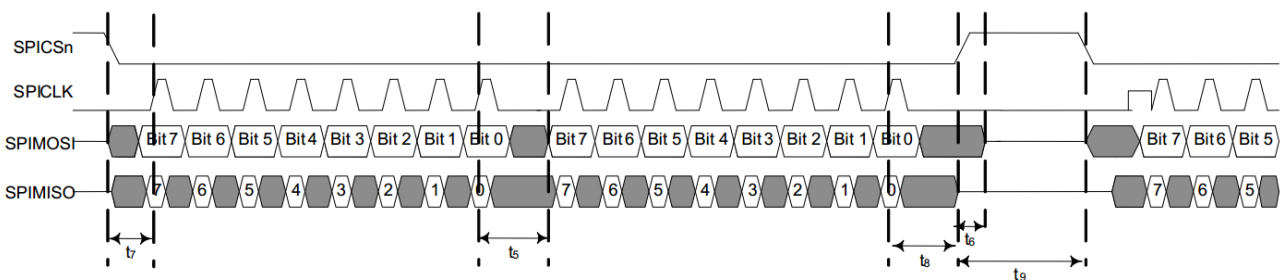

Figure 3 DWM1000 SPI Timing Diagram

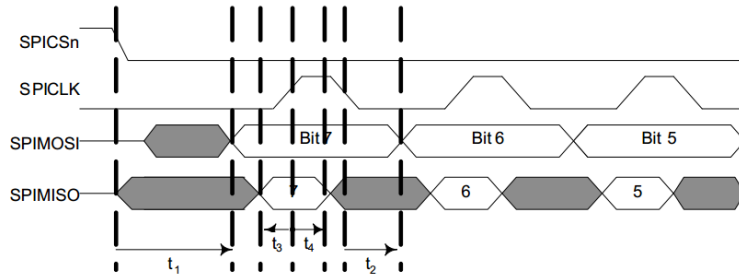

Figure 4: DWM1000 SPI Detailed Timing Diagram

Table 2: DWM1000 SPI Timing Parameters

Parameter	Min	Typ	Max	Unit	Description
SPICLK Period	50			ns	The maximum SPI frequency is 20 MHz when the CLKPLL is locked, otherwise the maximum SPI frequency is 3 MHz.
t ₁			38	ns	SPICSn select asserted low to valid slave output data
t ₂	12			ns	SPICLK low to valid slave output data
t ₃	10			ns	Master data setup time
t ₄	10			ns	Master data hold time
t ₅	32			ns	LSB last byte to MSB next byte
t ₆			10	ns	SPICSn de-asserted high to SPIMISO tri-state
t ₇	16			ns	Start time; time from select asserted to first SPICLK
t ₈	40			ns	Idle time between consecutive accesses
t ₉	40			ns	Last SPICLK to SPICSn de-asserted

1.4 General Purpose Input Output (GPIO)

The DWM1000 provides 8 configurable pins. On reset, all GPIO pins default to input. GPIO inputs, when appropriately configured, are capable of generating interrupts to the host processor via the IRQ signal.

GPIO0, 1, 2, & 3, as one of their optional functions, can drive LEDs to indicate the status of various chip operations. Any GPIO line being used to drive an LED in this way should be connected as shown. GPIO5 & 6 are used to configure the operating mode of the SPI as described in the DW1000 Datasheet [2].

See DW1000 Datasheet [2] and DW1000 User Manual [3] provide full details of the configuration and use of the GPIO lines

1.5 Always-On (AON) Memory

Configuration retention in lowest power states is enabled in DWM1000 by provision of an Always-On (AON) memory array with a separate power supply, VDDAON. The DWM1000 may be configured to upload its configuration to AON before entering a low-power state and to download the configuration when waking up from the low –power state.

1.6 One-Time Programmable (OTP) Memory

The DWM1000 contains a 56x32 -bit user programmable OTP memory on the DW1000 device that is used to store per chip calibration information.

1.7 Interrupts and Device Status

DWM1000 has a number of interrupt events that can be configured to drive the IRQ output pin. The default IRQ pin polarity is active high. A number of status registers are provided in the system to monitor and report data of interest. See DW1000 User Manual [3] for a full description of system interrupts and their configuration and of status registers.

1.8 MAC

A number of MAC features are implemented including CRC generation, CRC checking and receive frame filtering. See the DW1000 Datasheet [2] and DW1000 User Manual [3] for full details.

2 DWM1000 CALIBRATION

2.1 DWM1000 Calibration

Depending on the end-use applications and the system design, DWM1000 settings may need to be tuned. To help with this tuning a number of built in functions such as continuous wave TX and continuous packet transmission can be enabled. See the DW1000 User Manual [3] for further details.

2.1.1 Crystal Oscillator Trim

DWM1000 modules are calibrated at production to minimise initial frequency error to reduce carrier frequency offset between modules and thus improve receiver sensitivity. The calibration carried out at module production will trim the initial frequency offset to less than 2 ppm, typically.

2.1.2 Transmitter Calibration

In order to maximize range, DWM1000 transmit power spectral density (PSD) should be set to the maximum allowable for the geographic region in which it will be used. For most regions this is -41.3 dBm/MHz.

As the module contains an integrated antenna, the transmit power can only be measured over the air. The Effective Isotropic Radiated Power (EIRP) must be measured and the power level adjusted to ensure compliance with applicable regulations.

The DWM1000 provides the facility to adjust the transmit power in coarse and fine steps; 3 dB and 0.5 dB nominally. It also provides the ability to adjust the spectral bandwidth. These adjustments can be used to maximize transmit power whilst meeting regulatory spectral mask.

If required, transmit calibration should be carried out on a per DWM1000 module basis, see DW1000 User Manual [3] for full details¹.

2.1.3 Antenna Delay Calibration

In order to measure range accurately, precise calculation of timestamps is required. To do this the antenna delay must be known. The DWM1000 allows this delay to be calibrated and provides the facility to compensate for delays introduced by PCB, external components, antenna and internal DWM1000 delays.

To calibrate the antenna delay, range is measured at a known distance using two DWM1000 systems. Antenna delay is adjusted until the known distance and reported range agree. The antenna delay can be stored in OTP memory.

Antenna delay calibration must be carried out as a once off measurement for each DWM1000 design implementation. If required, for greater accuracy, antenna delay calibration should be carried out on a per DWM1000 module basis, see DW1000 User Manual [3] for full details.

3 DWM1000 PIN CONNECTIONS

3.1 Pin Numbering

DWM1000 module pin assignments are as follows (viewed from top):

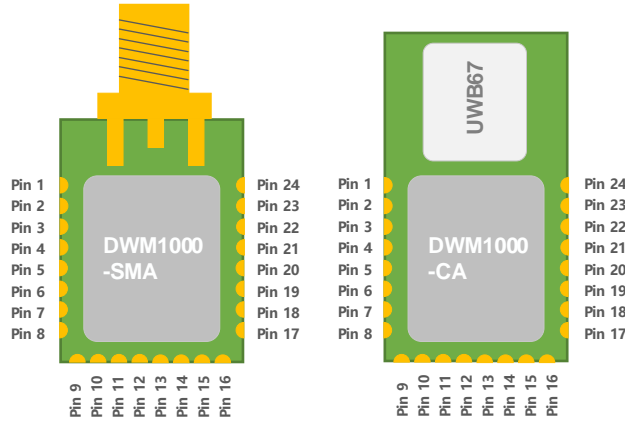

Figure 5: DWM1000 Pin Diagram

3.2 Pin Descriptions

Table 3: DWM1000 Pin functions

SIGNAL NAME	PIN	I/O (Default)	DESCRIPTION
Digital Interface			
SPICLK	20	DI	SPI clock
SPIMISO	19	DO (O-L)	SPI data output. Refer to DW1000 Datasheet for more details [2].
SPIMOSI	18	DI	SPI data input. Refer to DW1000 Datasheet for more details [2].
SPICSn	17	DI	SPI chip select. This is an active low enable input. The high-to-low transition on SPICSn signals the start of a new SPI transaction. SPICSn can also act as a wake-up signal to bring DW1000 out of either SLEEP or DEEPSLEEP states Refer to DW1000 Datasheet for more details [2].
WAKEUP	2	DIO	When asserted into its active high state, the WAKEUP pin brings the DW1000 out of SLEEP or DEEPSLEEP states into operational mode. If unused, this pin can be tied to ground.
EXTON	1	DO (O-L)	External device enable. Asserted during wake up process and held active until device enters sleep mode. Can be used to control external DC-DC converters or other circuits that are not required when the device is in sleep mode so as to minimize power consumption. Refer to DW1000 Datasheet for more details [2].
IRQ / GPIO8	22	DIO (O-L)	Interrupt Request output from the DWM1000 to the host processor. By default IRQ is an active-high output but may be configured to be active low if required. For correct operation in SLEEP and DEEPSLEEP modes it should be configured for active high operation. This pin will float in SLEEP and DEEPSLEEP states

			and may cause spurious interrupts unless pulled low. When the IRQ functionality is not being used the pin may be reconfigured as a general purpose I/O line, GPIO8.
GPIO7	4	DIO(I)	Defaults to operate as a SYNC input – refer [2]. THIS FUNCTIONALITY IS NOT APPLICABLE TO THE DWM1000. This pin may be reconfigured as a general purpose I/O pin, GPIO8 under software control.
GPIO6 / SPIPHA	9	DIO(I)	General purpose I/O pin. On power-up it acts as the SPIPHA (SPI phase selection) pin for configuring the SPI mode of operation. Refer to Section 5.2.2 and the DW1000 Datasheet for more details [2]. After power-up, the pin will default to a General Purpose I/O pin.
GPIO5/SPIPOL	10	DIO(I)	General purpose I/O pin. On power-up it acts as the SPIPOL (SPI polarity selection) pin for configuring the SPI operation mode. Refer to Section 5.2.2 and the DW1000 Datasheet for more details [2]. After power-up, the pin will default to a General Purpose I/O pin.
GPIO4	11	DIO(I)	General purpose I/O pin.
GPIO3 / TXLED	12	DIO(I)	General purpose I/O pin. It may be configured for use as a TXLED driving pin that can be used to light a LED following a transmission. Refer to the DW1000 User Manual [2] for details of LED use.
GPIO2/RXLED	13	DIO(I)	General purpose I/O pin. It may be configured for use as a RXLED driving pin that can be used to light a LED during receive mode. Refer to the DW1000 User Manual [2] for details of LED use.
GPIO1 /SFDLED	14	DIO(I)	General purpose I/O pin. It may be configured for use as a SFDLED driving pin that can be used to light a LED when SFD (Start Frame Delimiter) is found by the receiver. Refer to the DW1000 User Manual [2] for details of LED use.
GPIO0 / RXOKLED	15	DIO(I)	General purpose I/O pin. It may be configured for use as a RXOKLED driving pin that can be used to light a LED on reception of a good frame. Refer to the DW1000 User Manual [2] for details of LED use.
RSTn	3	DIO(O-H)	Reset pin. Active Low Output. May be pulled low by external open drain driver to reset the DW1000. Refer to DW1000 Datasheet for more details [2].
Power Supplies			
VDDAON	5	P	External supply for the Always-On (AON) portion of the chip.
VDD3V3	6.7	P	3.3 V supply pins. Note that for programming the OTP in the DWM1000 module this voltage may be increased to a nominal value of 3.8 V for short periods.
Ground			
GND	8,16,21 ,23,24	G	Common ground.

Table 4: Explanation of Abbreviations

ABBREVIATION	EXPLANATION
I	Input
IO	Input / Output
O	Output
G	Ground
P	Power Supply
PD	Power Decoupling
O-L	Defaults to output, low level after reset
O-H	Defaults to output, high level after reset
I	Defaults to input.

Note: Any signal with the suffix 'n' indicates an active low signal.

4 ELECTRICAL SPECIFICATIONS

4.1 Nominal Operating Conditions

Table 5: DWM1000 Operating Conditions

Parameter	Min	Typ	Max	Unit	Condition/Note
Operating temperature	-40		+85	°C	
Supply voltage VDDAON, VDD3V3	2.2	3.3	3.6	V	Normal operation
Supply voltage VDD3V3 for programming OTP	3.7	3.8	3.9	V	Note that for programming the OTP in the DWM1000 the VDD3V3 voltage must be increased to 3.8 V nominal for short periods.
Voltage on GPIO..7, WAKEUP, RSTn, SPICSn, SPIMOSI, SPICLK			3.6		Note that 3.6 V is the max voltage that may be applied to these pins

Note: Unit operation is guaranteed by design when operating within these ranges

4.2 DC Characteristics

Tamb = 25 °C, all supplies centred on typical values

Table 6: DWM1000 DC Characteristics

Parameter	Min	Typ	Max	Units	Condition/Note
Supply current DEEP SLEEP mode		200		nA	Total current drawn from all supplies.
Supply current SLEEP mode		550		nA	
Supply current IDLE mode		13.4		mA	
Supply current INT mode		3.5		mA	
TX: 3.3 V supplies (VDDAON, VDD)			140	mA	Channel 5: TX Power: 9.3 dBm/500 MHz
RX: 3.3 V supplies (VDDAON, VDD)			160	mA	Channel 5
Digital input voltage high	0.7*VDD			V	
Digital input voltage low			0.3VDD	V	
Digital output voltage high	0.7*VDD			V	Assumes 500Ω load
Digital output voltage low			0.3VDD	V	Assumes 500Ω load
Digital Output Drive Current GPIOx, IRQ SPIMISO EXTON	4 8 3	6 10 4		mA	

4.3 Receiver AC Characteristics

Tamb = 25 °C, all supplies centred on typical values

Table 7: DWM1000 Receiver AC Characteristics

Parameter	Min	Typ	Max	Unit	Condition/Note
Frequency range	3244		6999	MHz	
Channel bandwidth		500		MHz	
In-band blocking level		30		dBc	Continuous wave interferer
Out-of-band blocking level		55		dBc	Continuous wave interferer

4.4 Receiver Sensitivity Characteristics

Tamb = 25 °C, all supplies centred on typical values. 20 byte payload. These sensitivity figures assume an antenna gain of 0 dBi and should be modified by the antenna characteristics quoted in Table 12 depending on the orientation of the DWM1000.

Table 8: DWM1000 Typical Receiver Sensitivity Characteristics

Packet Error Rate	Data Rate	Receiver Sensitivity	Units	Condition/Note		
1%	110kbps	-102	dBm/500 MHz	Preamble2048	Carrier frequency offset ±10 ppm	All measurements performed on Channel 5, PRF 16 MHz Channel 2 is approximately 1 dB less sensitive
	850kpbs	-101	dBm/500 MHz	Preamble1024		
	6.8Mbps	-93	dBm/500 MHz	Preamble256		
10%	110kbps	-106	dBm/500 MHz	Preamble2048		
	850kpbs	-102	dBm/500 MHz	Preamble1024		
	6.8Mbps	-94	dBm/500 MHz	Preamble256		

4.5 Reference Clock AC Characteristics

Tamb = 25 °C, all supplies centred on typical values

Table 9: DWM1000 Reference Clock AC Characteristics

Parameter	Min	Typ	Max	Unit	Condition/Note
On-board crystal oscillator reference frequency		38.4		MHz	
On-board crystal trimming range		±25		ppm	Internally trimmed to +/- 2 ppm under typical conditions.
On-board crystal frequency stability with temperature			±30*	ppm	-40°C to +85°
On-board crystal aging			±3	Ppm/3year	@25°C ±2°C
Low Power RC Oscillator	5	12	15	KHz	

*By using the temperature monitoring capability of the DW1000 chip on the DWM1000 module it is possible to dynamically trim the crystal during run time to maintain the +/- 2ppm specification over the full temperature range of operation.

4.6 Transmitter AC Characteristics

Tamb = 25 °C, all supplies centred on typical values

Table 10: DWM1000 Transmitter AC Characteristics

Parameter	Min	Typ	Max	Unit	Condition/Note
Frequency range	3244		6999	MHz	
Channel Bandwidths		500		MHz	Channel 1, 2, 3 and 5
Output power spectral density (programmable)		-39	-35	dBm/MHz	See DW1000 Datasheet [2]
Power level range		37		dB	
Coarse Power level step		3		dB	
Fine Power level step		0.5		dB	
Output power variation with temperature		0.05		dB/°C	
Output power variation with voltage		2.73 3.34		dB/V	Channel 2 Channel 5

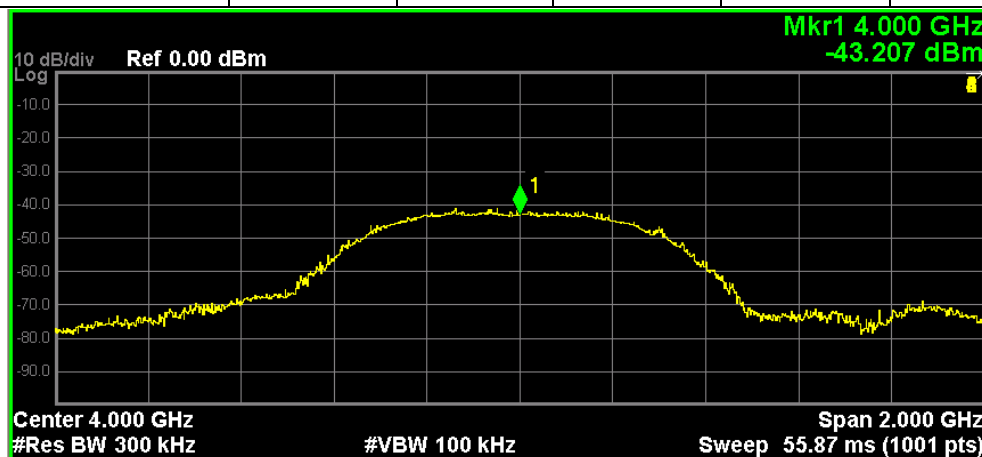

DWM1000-SMA Channel 2

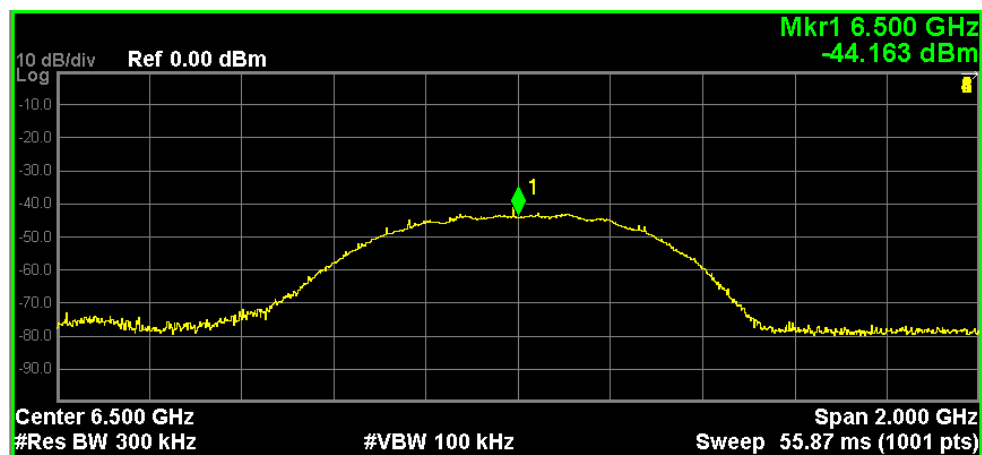

DWM1000-SMA Channel 5

4.7 Temperature and Voltage Monitor Characteristics

Table 11: DWM1000 Temperature and Voltage Monitor Characteristics

Parameter	Min	Typ	Max	Unit	Condition/Note
Voltage Monitor Range	2.4		3.75	V	
Voltage Monitor Precision		20		mV	
Voltage Monitor Accuracy		140		mV	
Temperature Monitor Range	-40		+100	°C	
Temperature Monitor Precision		0.9		°C	

4.8 Antenna Performance

DWM1000-SMA recommends the use of YCHIOT UWB antennas. The models are: UWB-SMA-C02, UWB-WB002, UWB-DA700, UWB-SMA20. DWM1000-CA uses the built-in ceramic antenna ACS5200HFAUWB. For specific antenna model parameters, please refer to the manual: *ap07-YCHIOT UWB antenna and cable product specification*.

4.9 Absolute Maximum Ratings

Table 12 DWM1000 Absolute Maximum Ratings

Parameter	Min.	Max.	Units
Voltage VDD3V3 / VDDAON	-0.3	4.0	V
Receiver Power		0	dBm
Temperature - Storage temperature	-40	+85	°C
Temperature – Operating temperature	-40	+85	°C
ESD (Human Body Model)		2000	V

5 APPLICATION INFORMATION

5.1 Application Board Layout Guidelines

When designing PCB board with dwm1000 module, the following points should be noted:

1. The antenna on the DWM1000 board should be away from metal and any material that will affect RF signal;
2. In order to fully run RF's advantages, copper materials should be laid in all parts of the product equipment board
3. Under the DWM1000 module, the PCB on both sides of top layer and bottom layer is not allowed to lay copper objects or place metal objects (for example, the design of placing batteries under the antenna is wrong).
4. The scheme on the right shows YCHIOT's Mini5-SMA Evaluation Board, equipped with self-developed DWM1000-SMA module and UWB rubber rod antenna, which has good ranging and positioning effect.

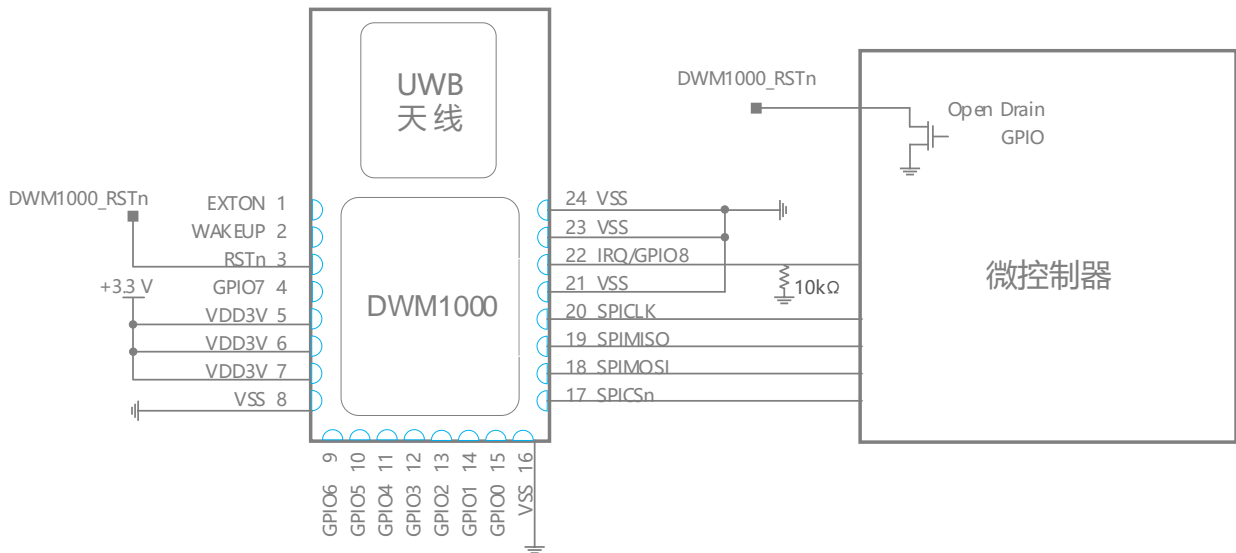

Figure 9: Example DWM1000 Application Circuit

5.2 Application circuit diagram

A simple integrated DWM1000 application circuit is only required to supply power to DWM1000, and connect the module to a master controller (SCM). Refer to Fig. 9.

5.2.1 SPI Bus

The SPI signal bus and mode configuration pins may need to be treated carefully if it is desirable to connect additional SPI devices to the SPI bus, or to configure the SPI for a non-default clock polarity of phase behaviour. Please see the DW1000 Datasheet [2] for a description of all SPI clock polarity and phase configurations, referred to as SPI modes.

The SPIMISO line may be connected to multiple slave SPI devices each of which is required to go open-drain when their respective SPICSn lines are de-asserted.

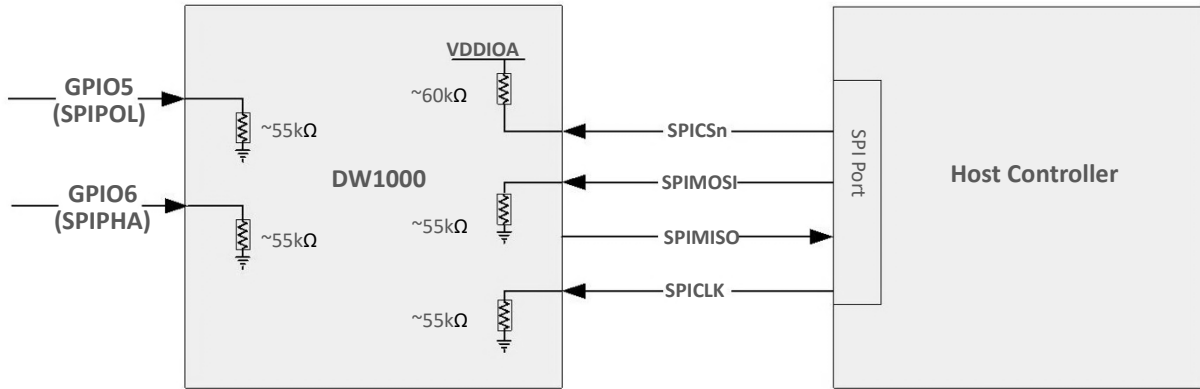

Figure 10: SPI Bus Connections

5.2.2 Configuring the SPI Mode

The SPI interface supports a number of different clock polarity and clock / data phase modes of operation. These modes are selected using GPIO5 & 6 as follows.

Table 5.2.2 DW1000 SPI Mode Configuration

GPIO 5 (SPIPOL)	GPIO 6 (SIPHA)	SPI Mode	Description (from the master / host point of view)
0	0	0	Data is sampled on the rising (first) edge of the clock and launched on the falling (second) edge
0	1	1	Data is sampled on the falling (second) edge of the clock and launched on the rising (first) edge.
1	0	2	Data is sampled on the falling (first) edge of the clock and launched on the rising (second) edge.
1	1	3	Data is sampled on the rising (second) edge of the clock and launched on the falling (first) edge.

Note: The 0 on the GPIO pins can either be open circuit or a pull down to ground. The 1 on the GPIO pins is a pull up to VDDIO.

GPIO 5 / 6 are sampled / latched on the rising edge of the RSTn pin to determine the SPI mode. They are internally pulled low to configure a default SPI mode 0 without the use of external components. If a mode other than 0 is required then they should be pulled up using an external resistor of value no greater than 10 kΩ to the VDDIO output supply.

5.2.3 Special instructions for Powering down the DWM1000

The DWM1000 has a very low DEEPSLEEP current (typ. 200 nA – see Table 6). The recommended practice is to keep the DWM1000 powered up and use DEEPSLEEP mode when the device is inactive.

In situations where the DWM1000 must be power-cycled (the +3.3V supply in figure 10 turned off and then back on) it is important to note that when power is removed the supply voltage will decay towards 0V at a rate determined by the characteristics of the power source and the amount of decoupling capacitance in the system.

In this scenario, power should only be reapplied to the DWM1000 when:

- VDDAON is above 2.3V or
- VDDAON has fallen below 100mV

Reapplying power while VDDAON is between 100mV and 2.3V can lead to the DWM1000 powering up in an unknown state which can only be recovered by fully powering down the device until the voltage on VDDAON falls below 100 mV.

6 PACKAGE INFORMATION

6.1 Module Drawings

Dwm1000 is in a 24 pin stamp package, and the pin definition is fully compatible with DWM1000. All measurements are given in millimeters.

Module	Size
<p>DWM1000-SMA</p>	<p>Technical drawing of the DWM1000-SMA module. It shows a side view on the left and a top view on the right. The side view indicates a total height of 30.0mm, with a SMA connector on top that is 6.5mm wide. The module's width is 3.2mm. The top view shows a rectangular footprint of 13.0mm width. The module is labeled 'DWM1000-SMA'.</p>
<p>DWM10000-CA</p>	<p>Technical drawing of the DWM10000-CA module. It shows a side view on the left and a top view on the right. The side view indicates a total height of 22.7mm. The module's width is 3.2mm. The top view shows a rectangular footprint of 13.0mm width. The module includes a UWB antenna labeled 'UWB 天线' and is labeled 'DWM1000-CA'.</p>

6.2 Module recommended package

Product	PCB Footprint	
<p>DWM1000-SMA</p>		
<p>DWM1000-CA</p>		

Table 6.2 Module Weight

Parameter	Min	Typ	Max	Units
Unit weight		3.2		g

7 SMT Production and Storage

7.1 SMT Production

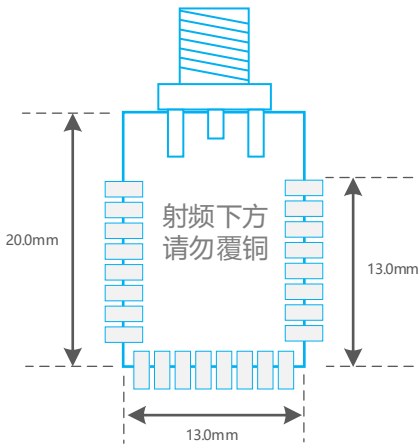
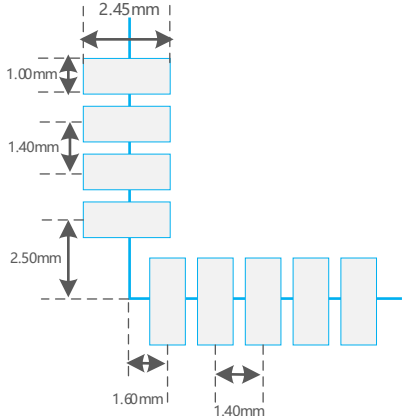
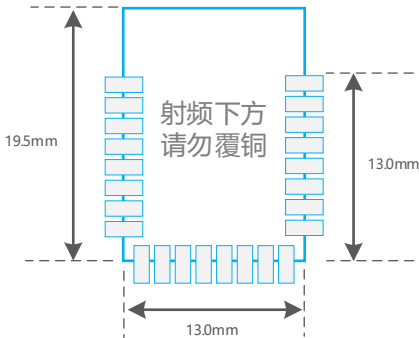
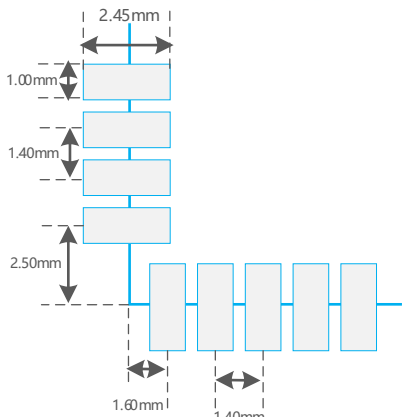
It is recommended to use manual welding for UWB module welding to avoid internal device movement caused by improper temperature control and secondary reflow soldering, which may affect product performance. If reflow soldering production is necessary, the recommended maximum reflow soldering temperature is 235-246 Celsius degree, and the maximum temperature cannot exceed 246 Celsius degree. The furnace temperature curve (lead-free SMT flow welding) and related parameters of the DWM1000 module during manufacturing are shown in Figure 6.3. The production suggestions are as follows, please read carefully:

- 1) It is recommended that the temperature of Reflow soldering should not exceed the temperature as shown in Fig. 6.3. It is recommended to reduce the overall curve by about 5 degrees. In summer, the temperature can be reduced appropriately;
- 2) The maximum number of reflow times for this module is 1. To avoid damage to the module due to repeated heating, it is recommended that customers install the module after completing the reflow soldering on the first side of the PCB;
- 3) For the first batch of SMT production, manufacturers should first pass through 5-10 modules in the furnace to check if the furnace temperature is suitable;

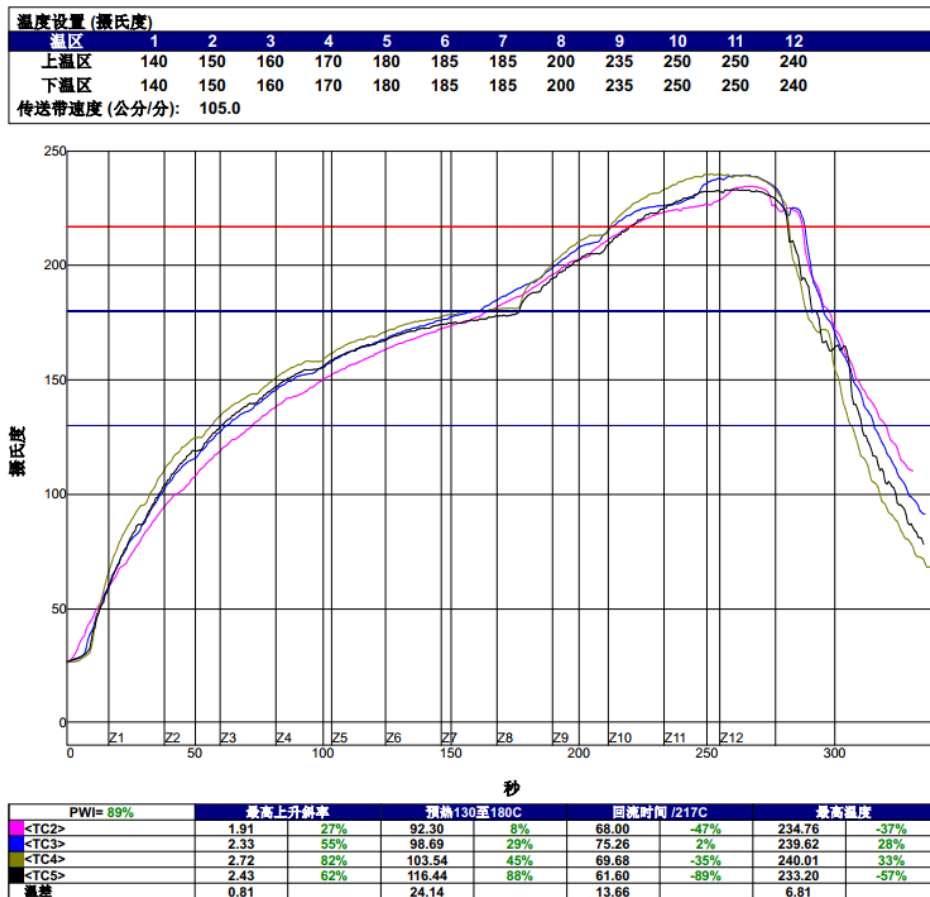







Figure 6.3 DWM1000 Module Solder Profile

7.2 Storage

Recommended storage conditions: temperature 23±5 Celsius degree, and relative humidity 35-60%. Under recommended storage conditions, the module can be stored in a sealed bag/box for 12 months. Under workshop conditions of 23±5

Celsius degree and relative humidity below 60%, the workshop life of the module after unpacking is 168 hours. Under these conditions, the module can be directly refluxed for production or other high-temperature operations. Otherwise, it is necessary to store the module in an environment with a relative humidity of less than 10% (such as a moisture-proof cabinet) to keep the module dry.

8 Ordering Information

Product	Demo	Model	Antenna interface	Status
UWB RF module		DWM1000-SMA	SMA	In-stock
UWB RF module		DWM1000-CA	Ceramic Antenna	In-stock
DWM1000-SMA Evaluation Board		Mini4-SMA	SMA	In-stock
DWM1000-CA Evaluation Board		Mini4-CA	Ceramic Antenna	In-stock
DWM1000-SMA Evaluation Board		Mini5-SMA	SMA	In-stock
DWM1000-CA Evaluation Board		Mini5-CA	Ceramic Antenna	In-stock

For technical question, retail and purchase of DWM1000-SMA and DWM1000-SMA evaluation board, please contact:

Mr. Lin 15606880772 (BD)

Mr. Wu 13296707815 (Technical)

QQ: 171932915

WeChat: 15606880772

Purchase Link:

Official Website: <http://www.ychiot.com/>

9 GLOSSARY

Abbreviation	Full Title	Explanation
EIRP	Equivalent Isotropically Radiated Power	The amount of power that a theoretical isotropic antenna (which evenly distributes power in all directions) would emit to produce the peak power density observed in the direction of maximum gain of the antenna being used
ETSI	European Telecommunication Standards Institute	Regulatory body in the EU charged with the management of the radio spectrum and the setting of regulations for devices that use it
FCC	Federal Communications Commission	Regulatory body in the USA charged with the management of the radio spectrum and the setting of regulations for devices that use it
GPIO	General Purpose Input / Output	Pin of an IC that can be configured as an input or output under software control and has no specifically identified function
IEEE	Institute of Electrical and Electronic Engineers	Is the world's largest technical professional society. It is designed to serve professionals involved in all aspects of the electrical, electronic and computing fields and related areas of science and technology
LIFS	Long Inter-Frame Spacing	Defined in the context of the IEEE 802.15.4-2011 [1] standard
LNA	Low Noise Amplifier	Circuit normally found at the front-end of a radio receiver designed to amplify very low level signals while keeping any added noise to as low a level as possible
LOS	Line of Sight	Physical radio channel configuration in which there is a direct line of sight between the transmitter and the receiver
NLOS	Non Line of Sight	Physical radio channel configuration in which there is no direct line of sight between the transmitter and the receiver
PGA	Programmable Gain Amplifier	Amplifier whose gain can be set / changed via a control mechanism usually by changing register values
PLL	Phase Locked Loop	Circuit designed to generate a signal at a particular frequency whose phase is related to an incoming "reference" signal.
PPM	Parts Per Million	Used to quantify very small relative proportions. Just as 1% is one out of a hundred, 1 ppm is one part in a million
RF	Radio Frequency	Generally used to refer to signals in the range of 3 kHz to 300 GHz. In the context of a radio receiver, the term is generally used to refer to circuits in a receiver before down-conversion takes place and in a transmitter after up-conversion takes place
RTLS	Real Time Location System	System intended to provide information on the location of various items in real-time.
SFD	Start of Frame Delimiter	Defined in the context of the IEEE 802.15.4-2011 [1] standard.

SPI	Serial Peripheral Interface	An industry standard method for interfacing between IC's using a synchronous serial scheme first introduced by Motorola
TCXO	Temperature Controlled Crystal Oscillator	A crystal oscillator whose output frequency is very accurately maintained at its specified value over its specified temperature range of operation.
TWR	Two Way Ranging	Method of measuring the physical distance between two radio units by exchanging messages between the units and noting the times of transmission and reception. Refer to Decawave's website for further information
TDOA	Time Difference of Arrival	Method of deriving information on the location of a transmitter. The time of arrival of a transmission at two physically different locations whose clocks are synchronized is noted and the difference in the arrival times provides information on the location of the transmitter. A number of such TDOA measurements at different locations can be used to uniquely determine the position of the transmitter. Refer to Decawave's website for further information.
UWB	Ultra Wideband	UWB (Ultra Wideband) A radio scheme employing channel bandwidths of, or in excess of, 500MHz
WSN	Wireless Sensor Network	A network of wireless nodes intended to enable the monitoring and control of the physical environment

10 Documentation

Topic	DWM1000 datasheet
Version	YCHIOT DWM1000 DATASHEET V1.2
Created Time	2019-5-9
Reference	<p>[1] IEEE802.15.4-2011 or “ IEEE Std 802.15.4™- 2011 ” (Revision of IEEE Std 802.15.4-2006). IEEE Standard for Local and metropolitan area networks – Part 15.4: Low-Rate Wireless Personal Area Networks (LRWPANs). IEEE Computer Society Sponsored by the LAN/MAN Standards Committee. Available from http://standards.ieee.org/</p> <p>[2] Qorvo DW1000 Datasheet https://www.qorvo.com/products/p/DW1000</p> <p>[3] Qorvo DWM1000 User Manual https://www.qorvo.com/products/p/DWM1000</p> <p>[4] Partron (Now manufactured by Abracon) Dielectric Chip Antenna, P/N ACS5200HFAUWB (Now ACA-107-T), www.digikey.com also see www.abracon.com</p>
Last Updated	2024/01/01

Contact	Date	Revise
Lynn	2019-05-09	V1.0 Release
Lynn	2023-01-01	V1.1 Update the diagram in chapter 6 Update the EVB board information in chapter 7
Lynn	2024-01-01	V1.2 Modify information about DWM1000-CA and update module footprint